

A photograph of a rural landscape in Bangladesh. A paved road curves through the scene, with a person riding a rickshaw away from the camera. The background features lush green fields, trees, and a hazy sky. The text 'Solarmarkt im Hinterland von Bangladesch' is overlaid in white.

Solarmarkt

im Hinterland von Bangladesch

Nancy Wimmer
www.microsolar.com



1996



ein Solar Home System ist

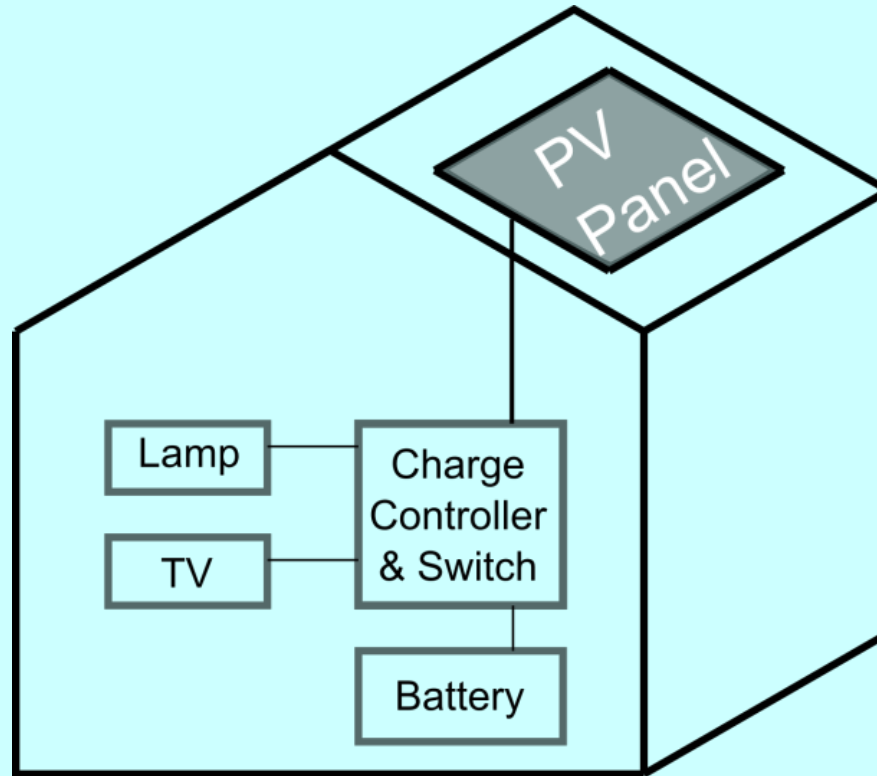

ein unspektakuläres Produkt ...

...mit spektakulärem Erfolg

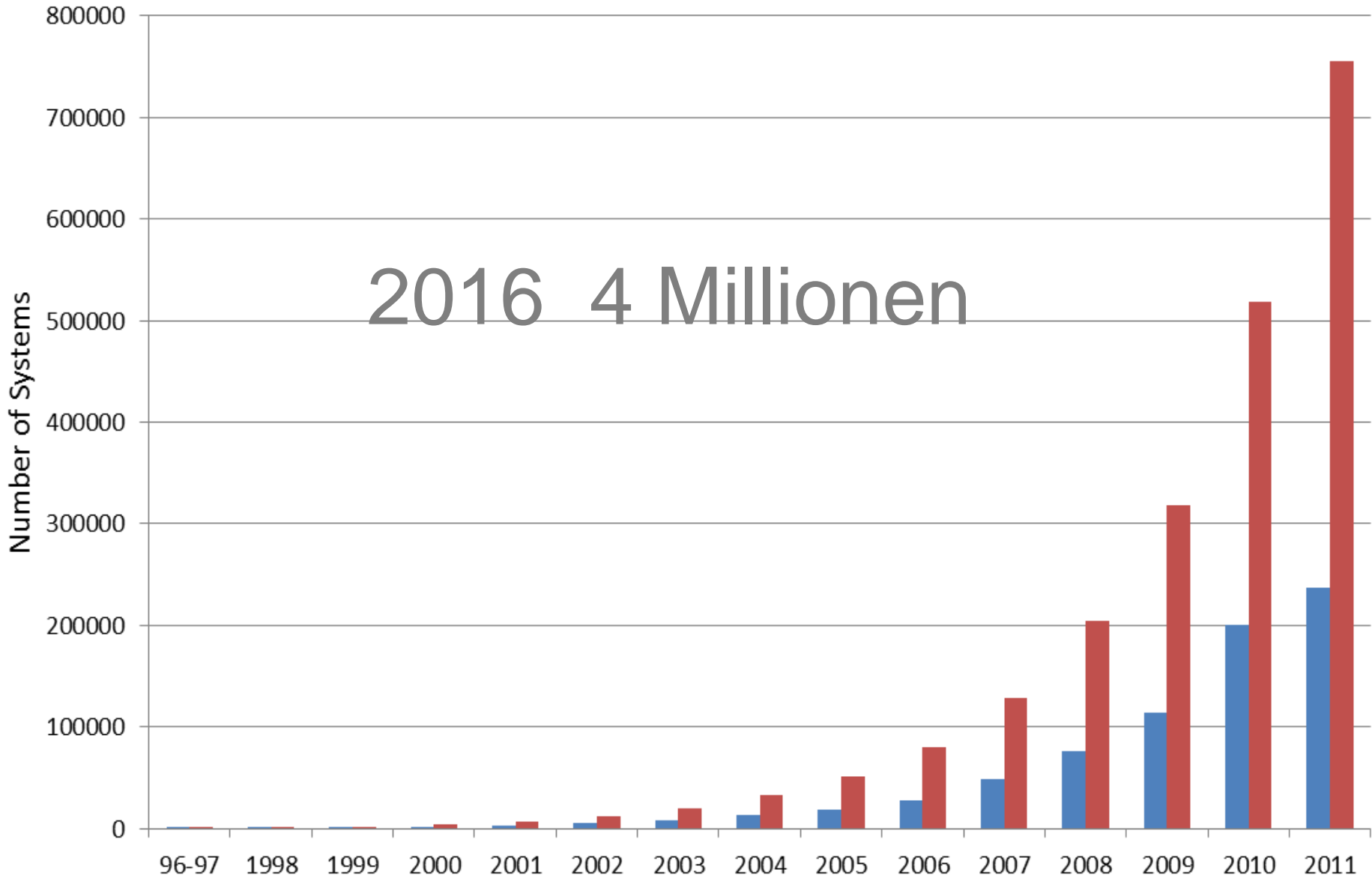

ein schwieriger Markt



arm

ein schwieriger Markt



entlegen

ein schwieriger Markt



riskant



???

Geschäftsmodell
für's Hinterland

viele verstreute Filialen



Service! Alles aus einer Hand!



Mitarbeiter leben im Dorf

jeder Ingenieur: ein Trainer



jede Filiale: ein Schulungszentrum

Kontroller



sales / year

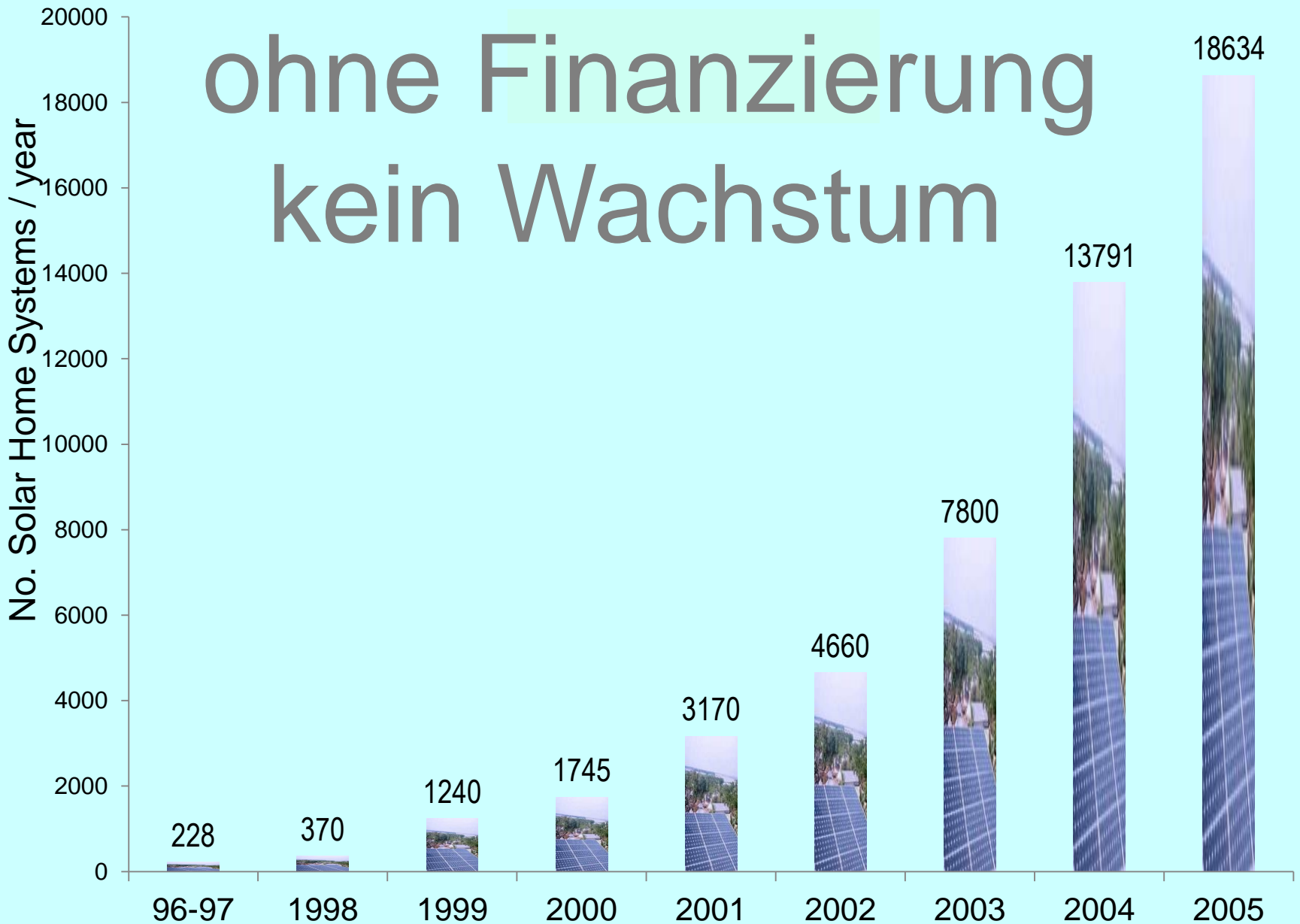

ohne Finanzierung
kein Wachstum

Weltbank

A photograph of a rural village scene. In the foreground, there is a body of water reflecting the sky and the buildings. The middle ground shows several traditional houses with thatched roofs. One of the houses has a solar panel mounted on its roof. The background is filled with lush green trees and vegetation. The overall scene is peaceful and depicts a rural setting with modern energy infrastructure.

Weltbank-Projekt

Rural Electrification and
Renewable Energy

Development

RERED

RERED:

Solarmarkt + Wettbewerb

neu!





Starthilfe für Firmen
Kundenkredit
Qualitätsprodukt



Geschäftsmodell



\$ 400 mio Kredit



fähiges Management

die Ressourcen





Unternehmer
Alam Zahirul



meine Beschützer

Vertrieb im Hinterland

70.000 Dörfer

7.101 Filialen



30.000 Jobs



thank you

micro
solar

**THE
MARKETMAKERS**

Solar for the Hinterland of Bangladesh

NANCY WIMMER

